



A-LED-CF40W2F

Cabinet Frame

600 × 337.5 Indoor LED

- Highly integrated and lightweight design.
- Easy to disassemble lamp board, power supply, and receiving card on the front side with high-precision aluminum die casting cabinet design.
- Compatible cabinet structure with COB(A-4007BW-2FB/A-40XXBW-2FC), HOB(A-40XXAW-2FQ), SMD(DS-D40XXCW-2F).
- The packaging adopts recyclable materials, and the whole process of production achieves green and low-carbon standards.
- Please note: Module and cabinet structure should be separately ordered.

▪ Dimension

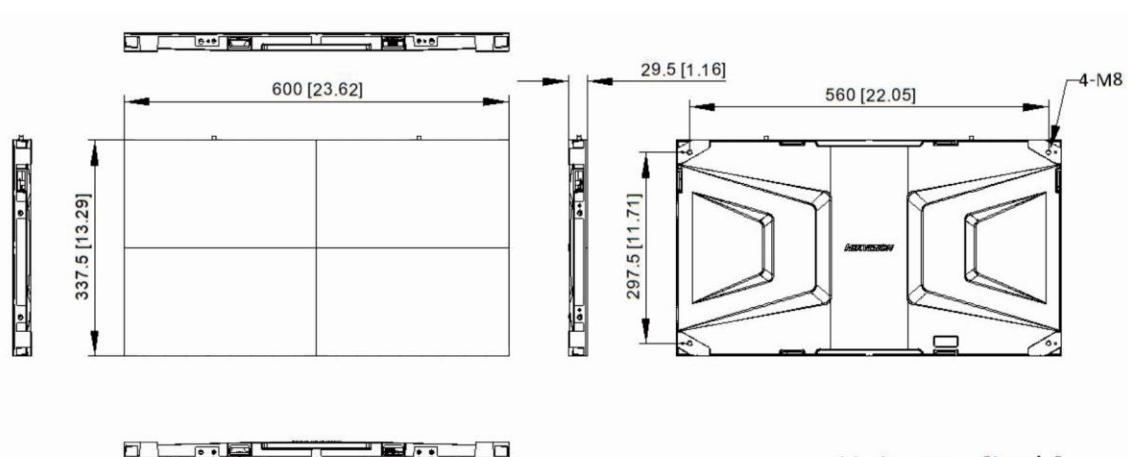

Unit: mm [inch]



▪ Specification

Product Model	
Product Model	A-LED-CF40W2F
Product Type	
Product Type	LED Display Structure
Cabinet	
Dimensions (W × H × D)	600 (W) × 337.5 (H) × 29.5 (D) mm (23.622" × 13.287" × 1.161")
Area	0.2025 m ²
Weight	3.4 kg
Cabinet Material	Aluminium die casting
Maintenance Method	Front maintenance for all components
Power	
Input Voltage	100~240 VAC ± 10%
Working Environment	
Working Temperature	-10 °C to 40 °C (14 °F to 104 °F)
Working Humidity	10% to 60% RH (without condensation)
Storage Temperature	-20 °C to 60 °C (-4 °F to 140 °F)
Storage Humidity	10% to 85% RH (without condensation)
General	
Package Dimensions (W × H × D)	1-in-1 : 687X405X74mm; 5-in-1 : 708X393X433mm
Packing List	Regulatory Compliance and Safety Information × 1 Connecting screws, light beads, driver IC, iron sheets
G.W.	4.5 kg (1 package in 1 box)
Net Weight	3.4 kg
Bracket	
Modular Bracket	A-L116033W 1*1; A-L126033W 1*2; A-226033W 2*2